

Page01	Power IN
Page02	SOM Interface
Page03	Ethernet-01
Page04	Ethernet-02
Page05	TF & QSPI Flash
Page06	WIFI&BT
Page07	Audio&SPK&SPDIF
Page08	USB3
Page09	USB2
Page10	SPI to UART
Page11	CAN1 & CAN2
Page12	MIPI CSI1&CSI2
Page13	MIPI DSI&HDMI&LV
Page14	RS232 & RS485
Page15	GPIO&RTC&EEPROM&



Polyhex Technology Company Limited
www.debix.io www.polyhex.net

This document contains information proprietary to Polyhex and shall not be used for engineering design, procurement or manufacture in whole or in part without the express written permission of Polyhex Semiconductors.

Sheet: /
 File: DEBIX SOM A IO Board_SCH.kicad_sch

Title: DEBIX SOM A I/O Board (BMB-08)

Size: A4	Date:	Rev: V1.1
KiCad E.D.A. eeschema (6.0.8)		Id: 1/16

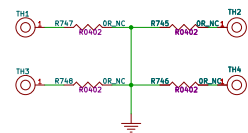
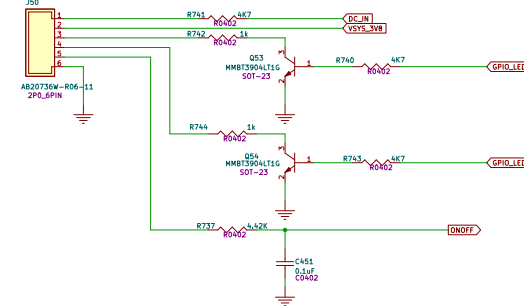
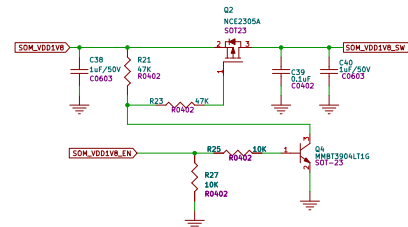
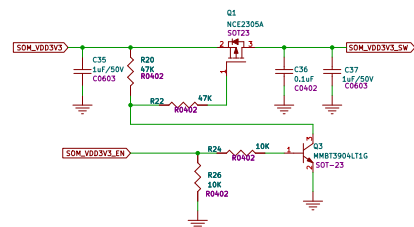
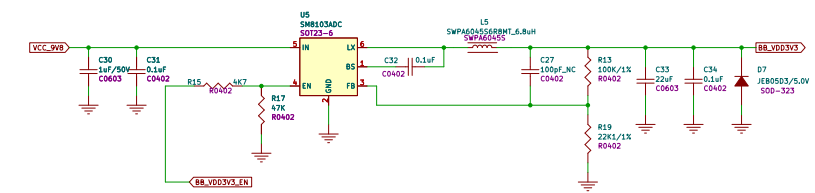
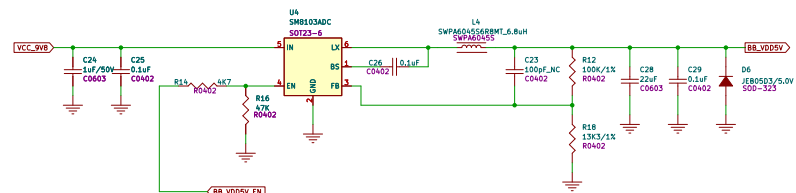
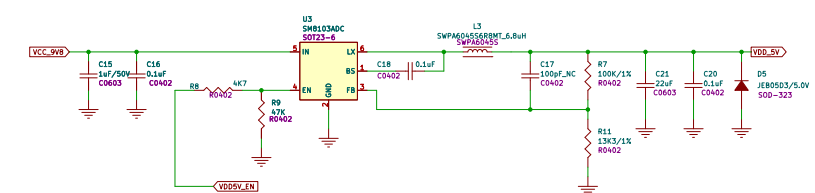
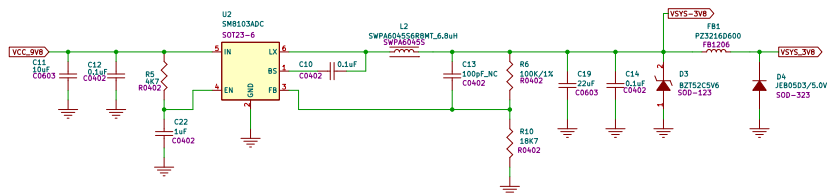
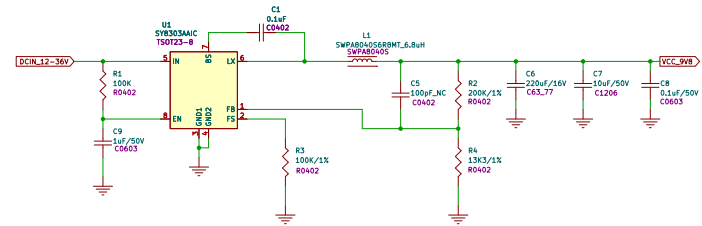
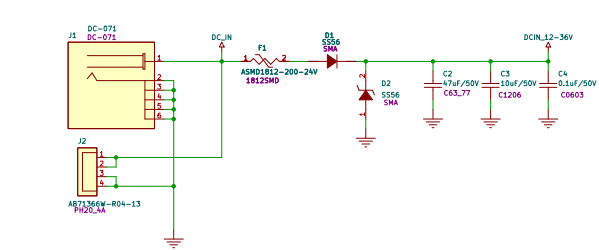

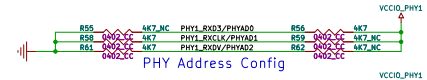
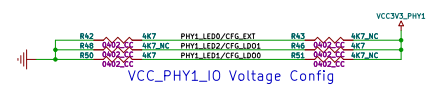
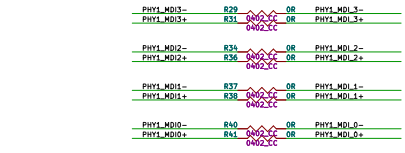
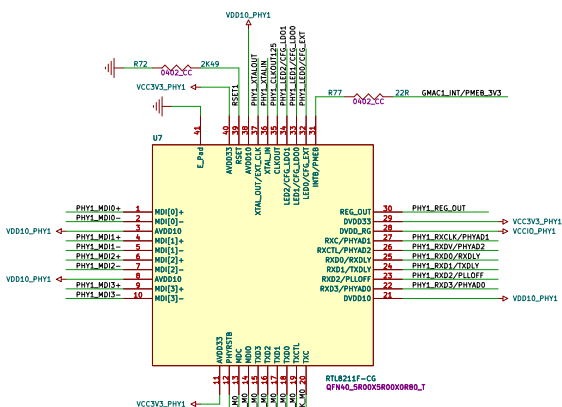

Pull-up for additional 2ns delay to RXC for data latching

Pull-up for additional 2ns delay to TXC for data latching

Pull-up to disable PLL @ ALDPS mode(Low power mode)

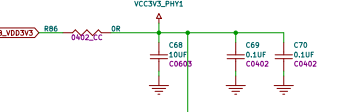
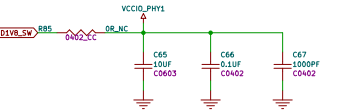
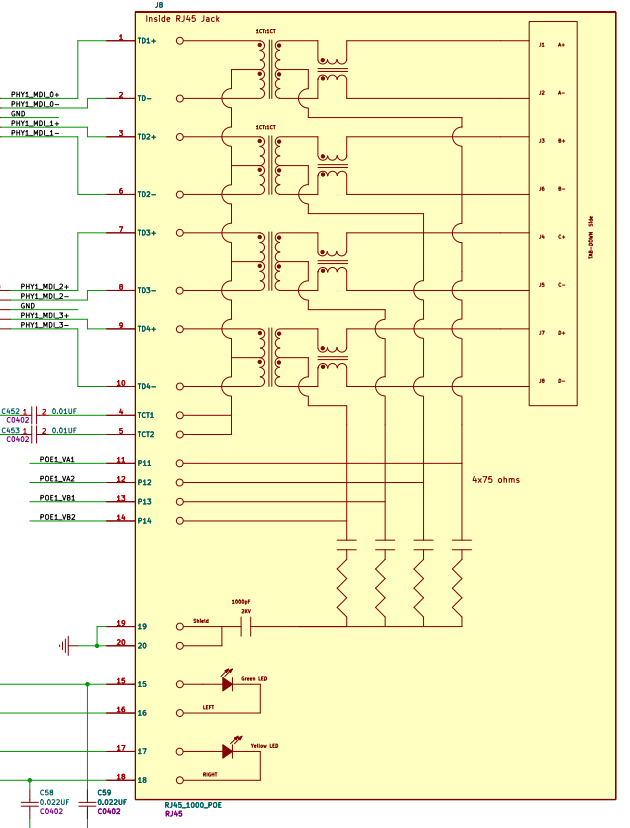
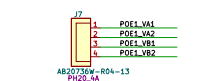
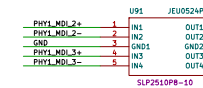
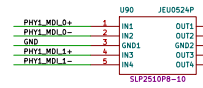
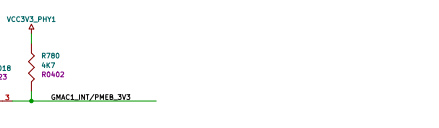
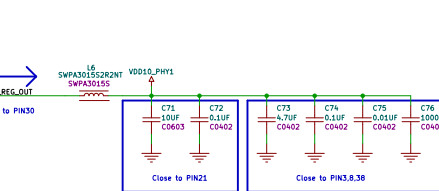
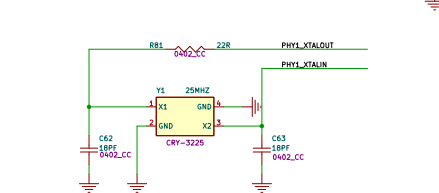
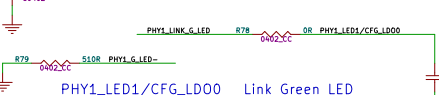
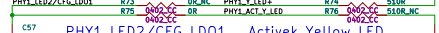

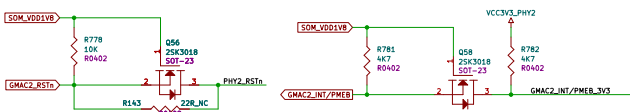
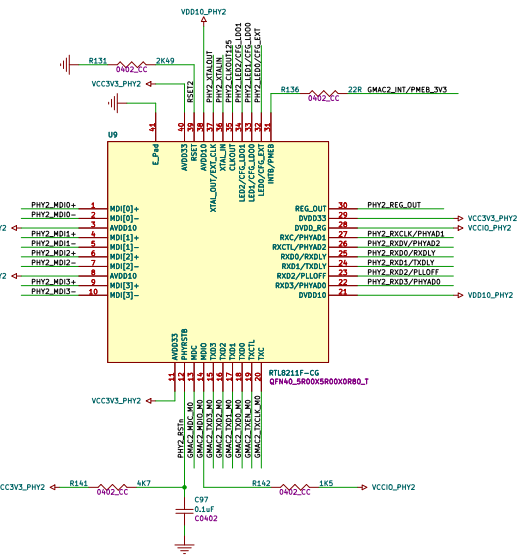
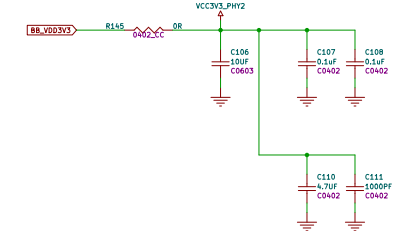
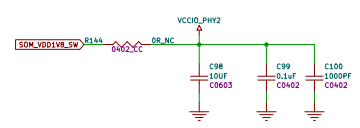
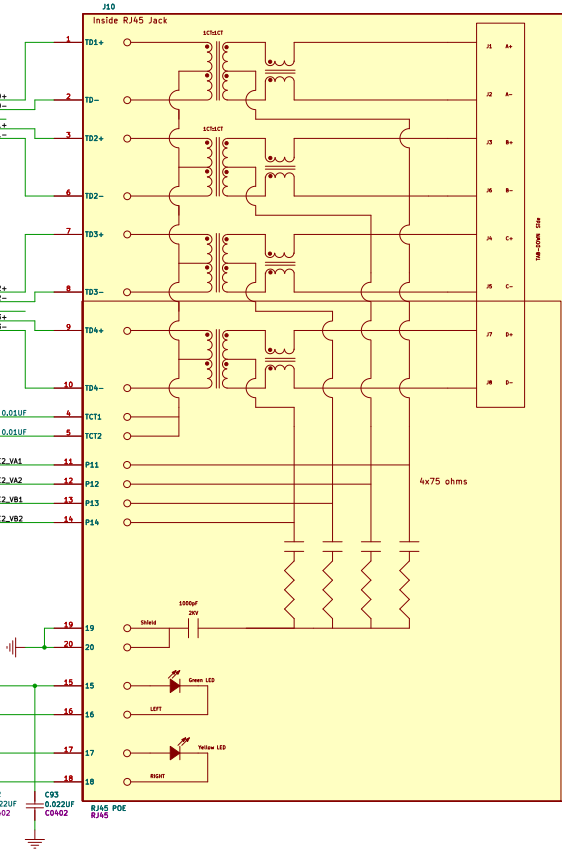
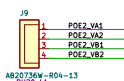
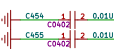
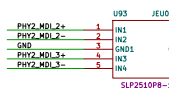
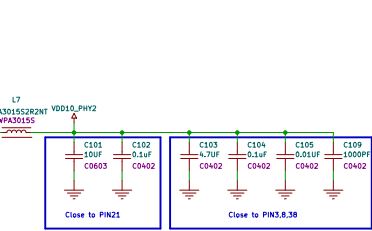
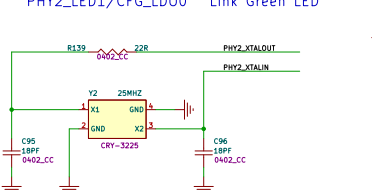
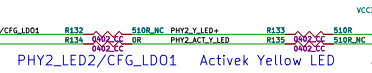
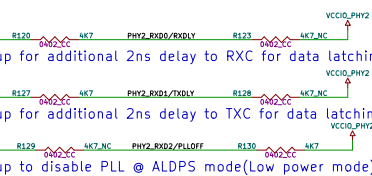
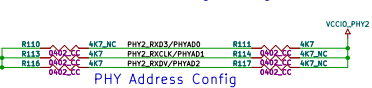
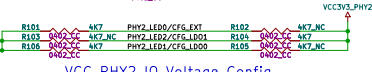
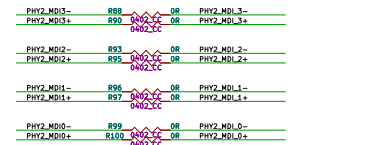

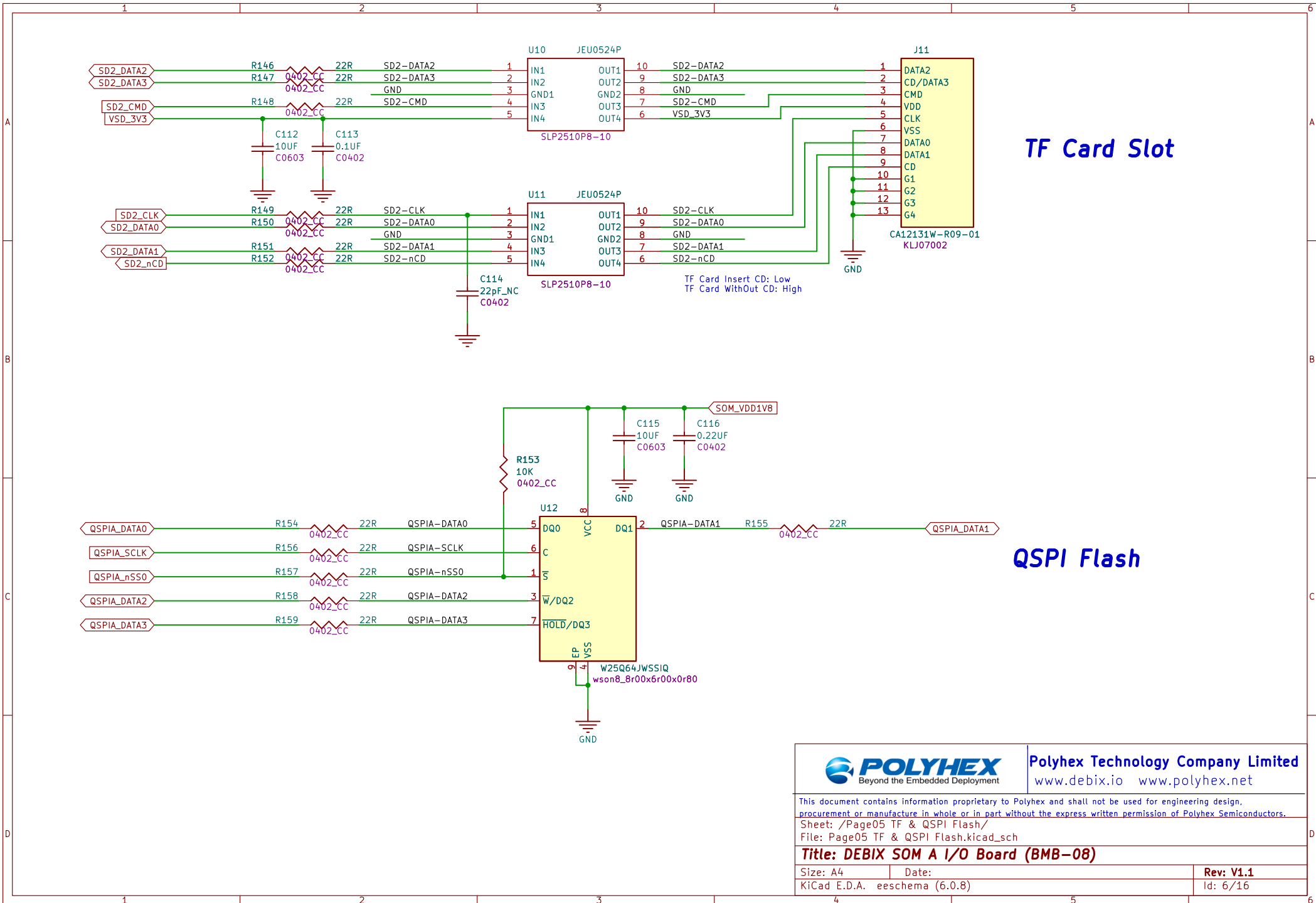

Polyhex Technology Company Limited
www.debix.io www.polyhex.net

This document contains information proprietary to Polyhex and shall not be used for engineering design, procurement or manufacture in whole or in part without the express written permission of Polyhex Semiconductors.
 Sheet: /Page05 TF & QSPI Flash/
 File: Page05 TF & QSPI Flash.kicad_sch

Title: DEBIX SOM A I/O Board (BMB-08)

Size: A4	Date:	Rev: V1.1
KiCad E.D.A. eeschema (6.0.8)		Id: 6/16

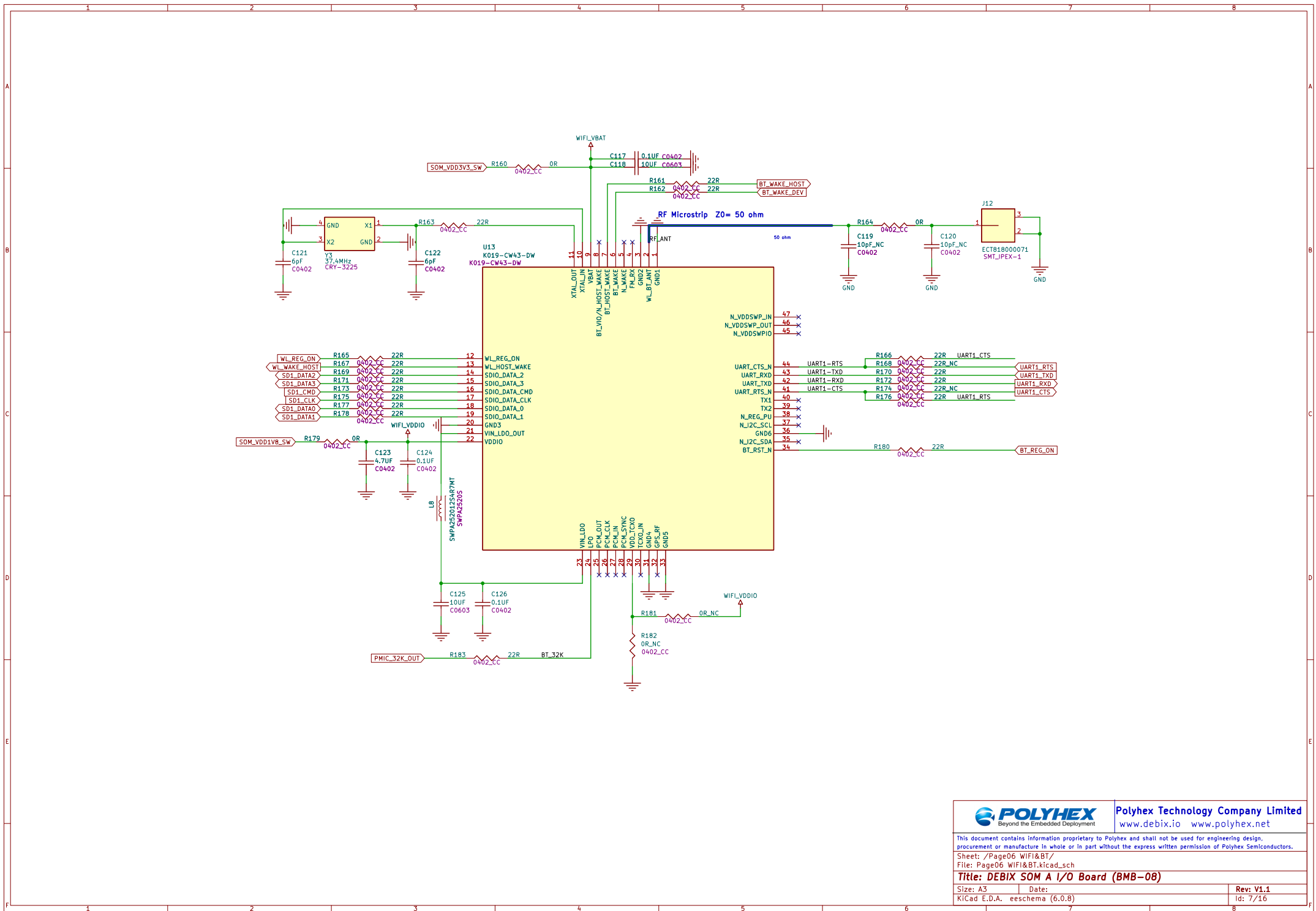

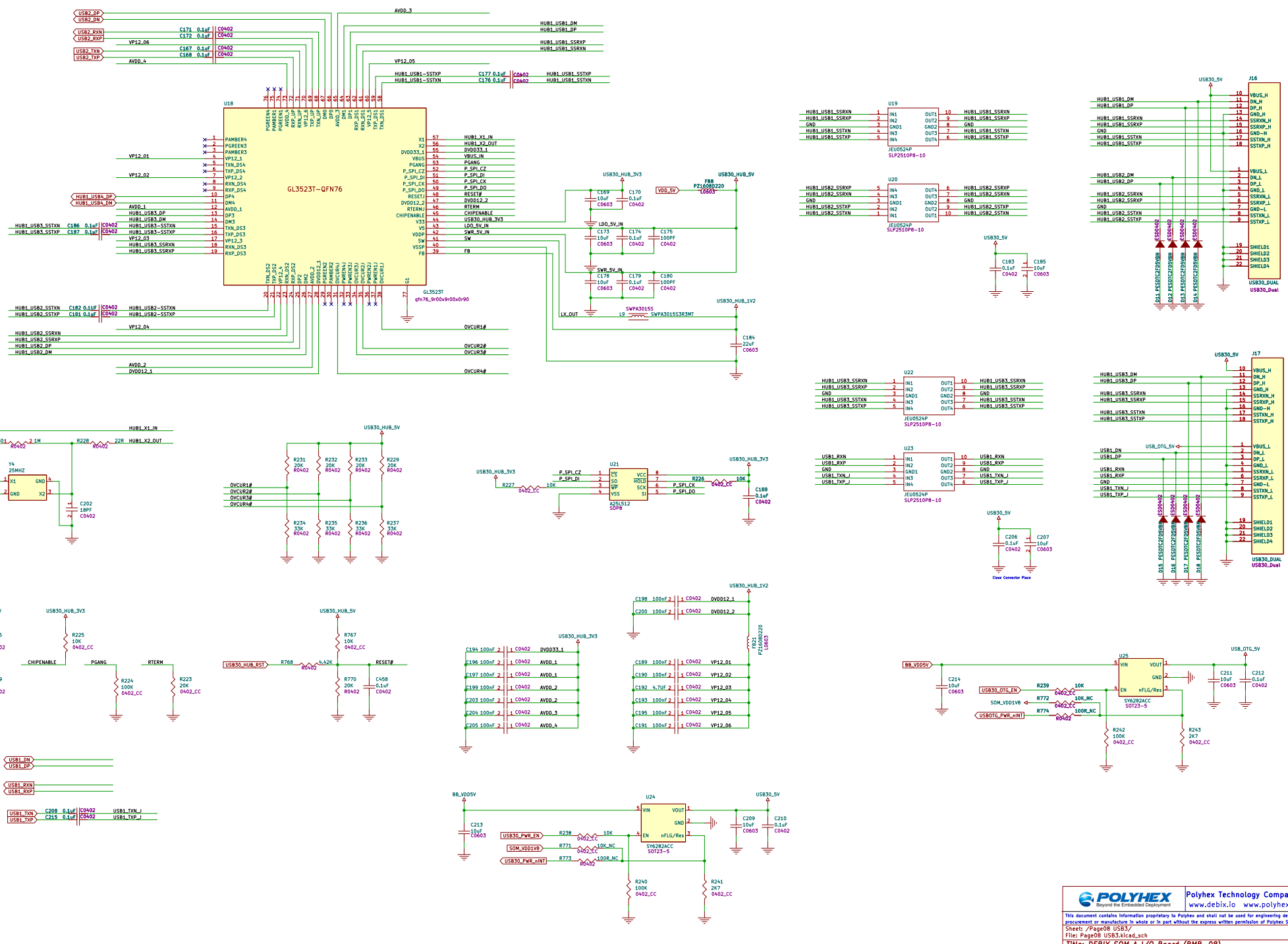

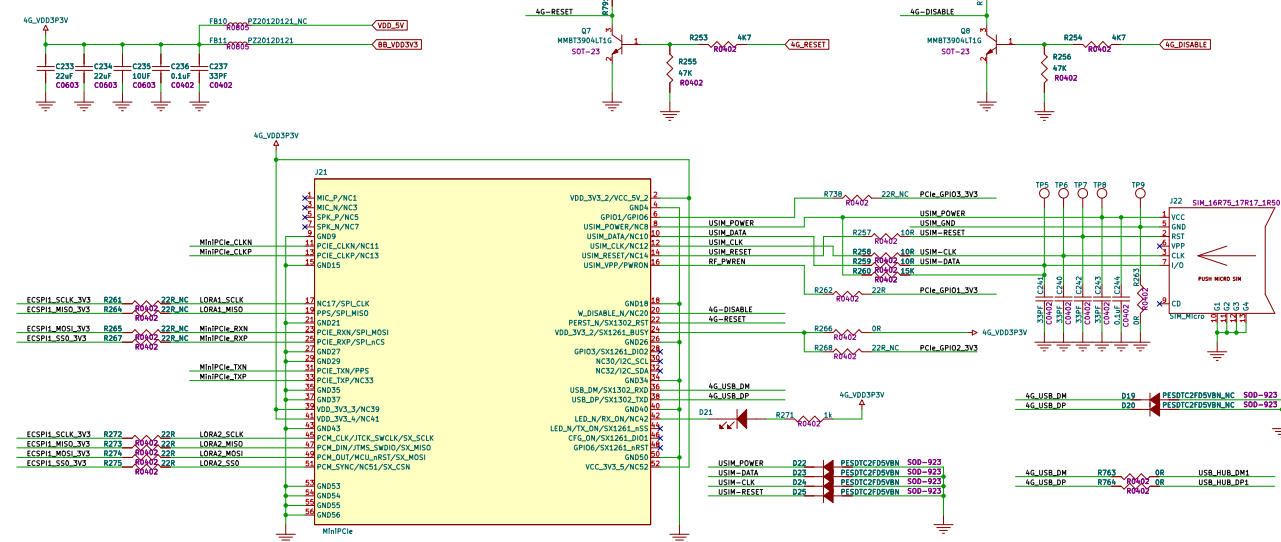
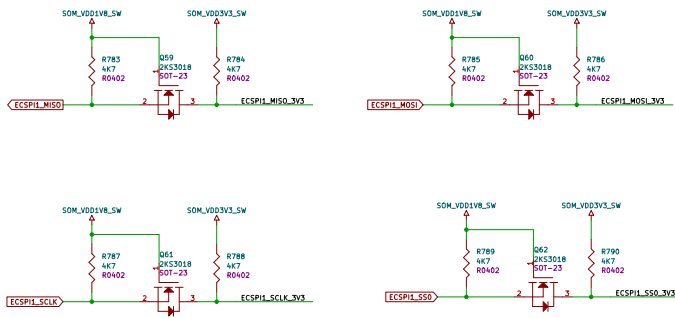
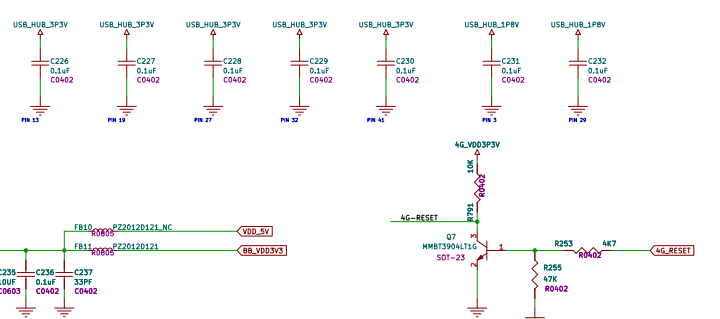
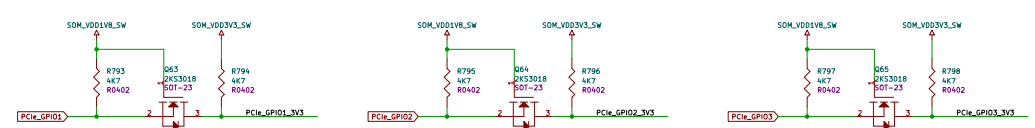
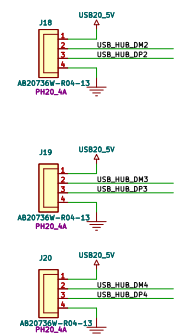
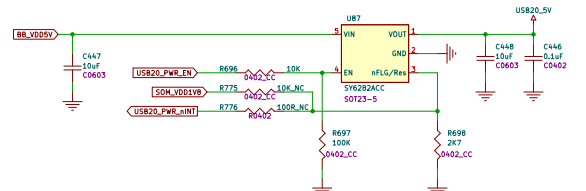
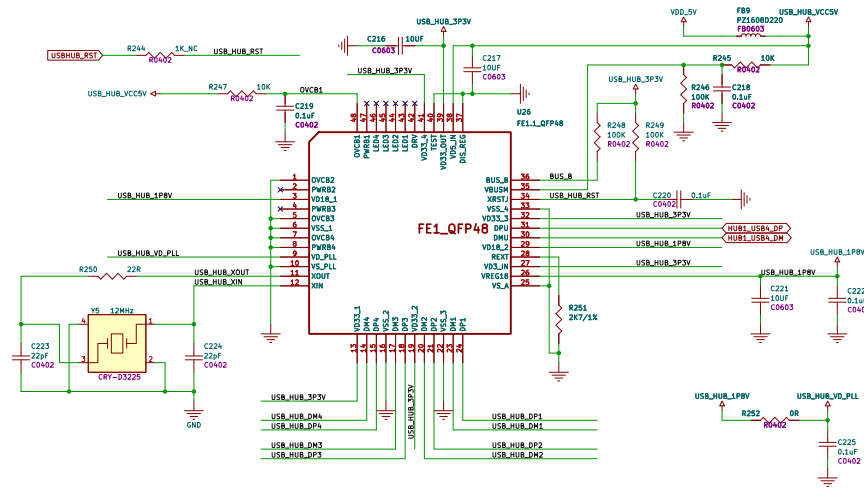

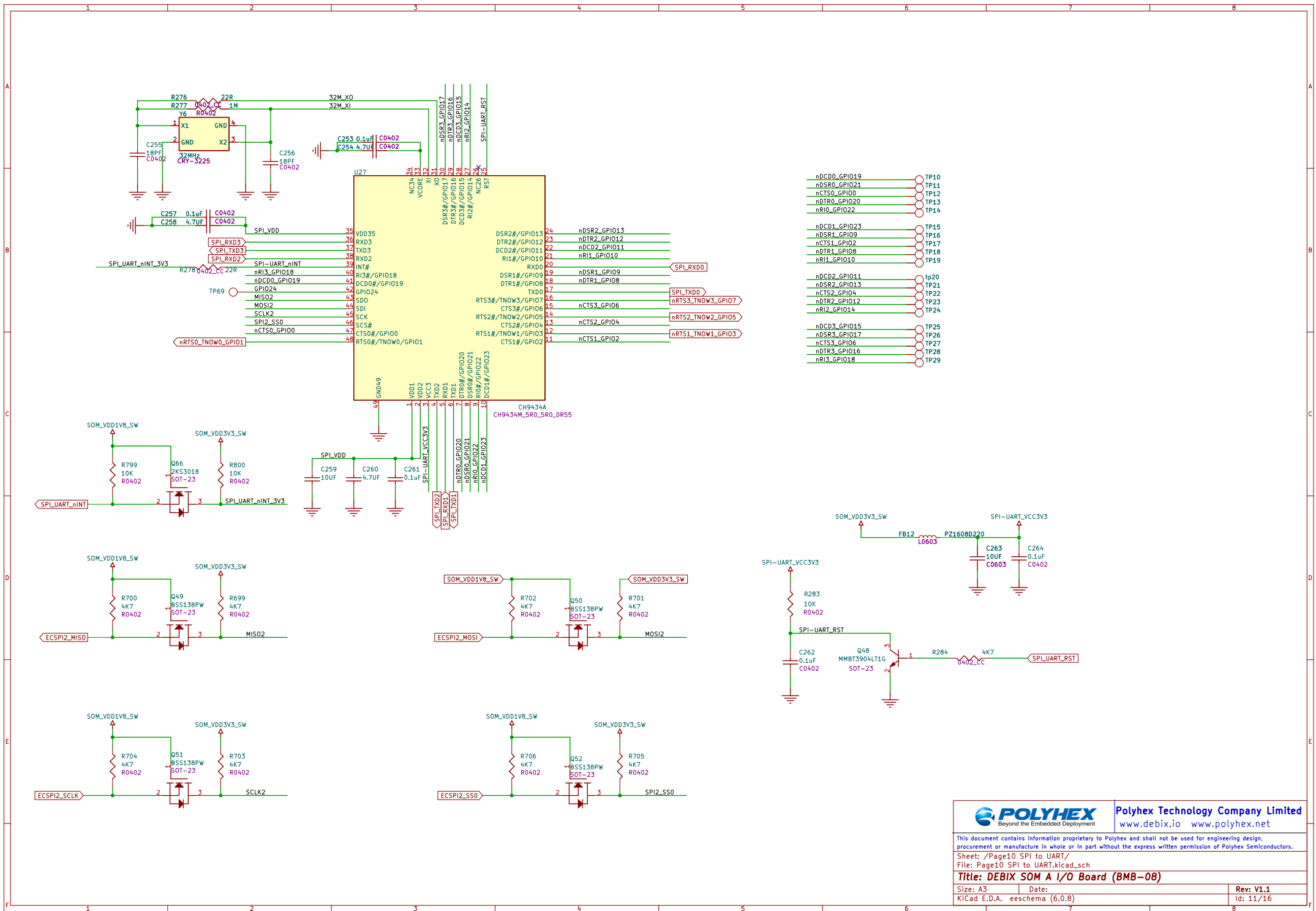

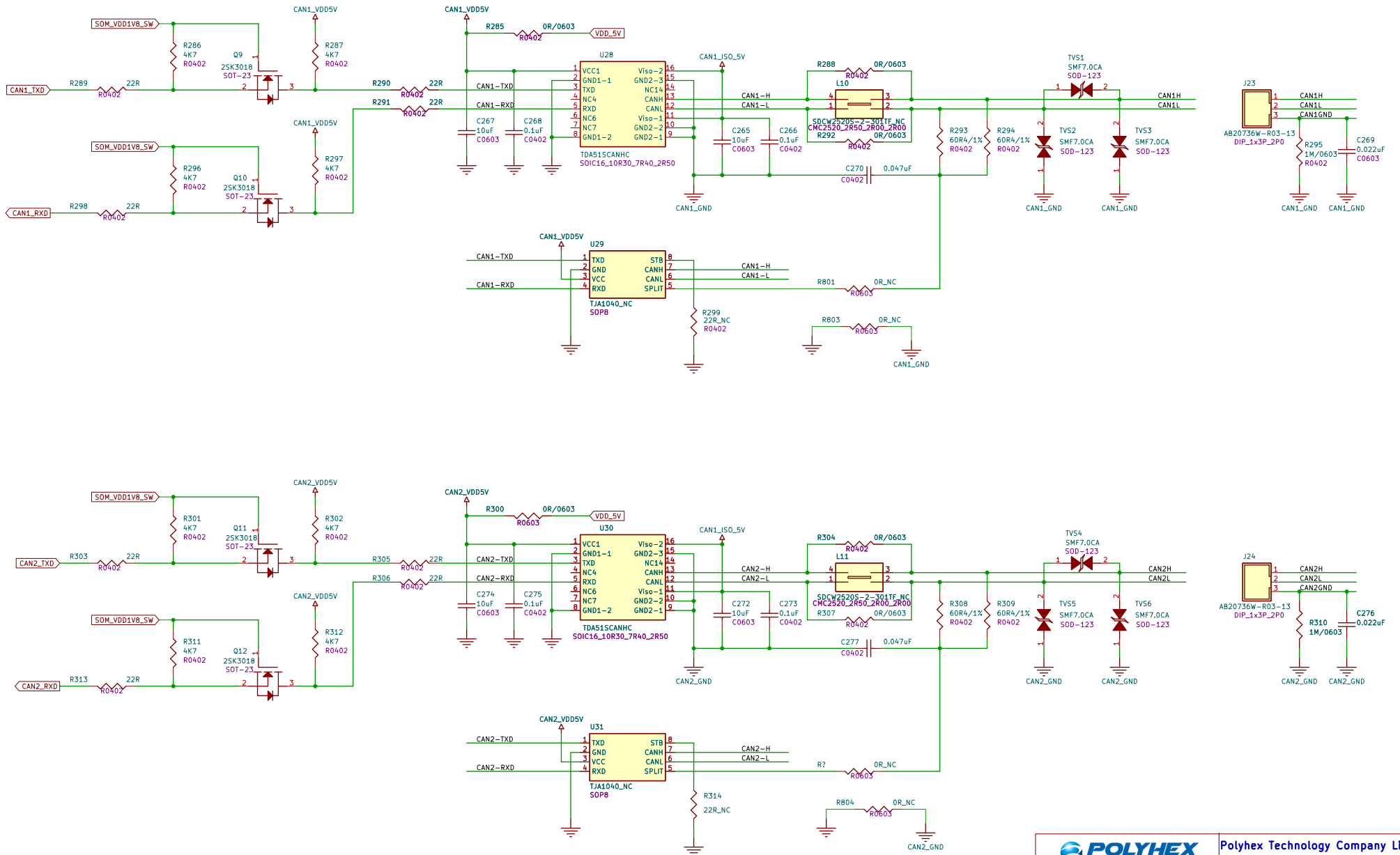

 Beyond the Embedded Deployment		Polyhex Technology Company Limited www.debix.io www.polyhex.net	
<small>This document contains information proprietary to Polyhex and shall not be used for engineering design, procurement or manufacture in whole or in part without the express written permission of Polyhex Semiconductors.</small>			
<small>Sheet: /Page11 CAN1 & CAN2/ File: Page11 CAN1 & CAN2.kicad_sch</small>			
Title: DEBIX SOM A I/O Board (BMB-08)			
<small>Size: A3</small>	<small>Date:</small>	<small>Rev: V1.1</small>	
<small>KiCad E.D.A.</small>		<small>eeschema (6.0.8)</small>	<small>Id: 12/16</small>

